

Features

- MINIATURE SIL PACKAGE
- LOW COST VERSION
- DATA RATES UP TO 40 KBPS
- SINGLE 2.2 TO 10v SUPPLY
- 868.45, 869.85 & 914.5 MHz VERSIONS
- INDUSTRY PIN COMPATIBLE
- EN 300-220 COMPLIANT MODULE
-

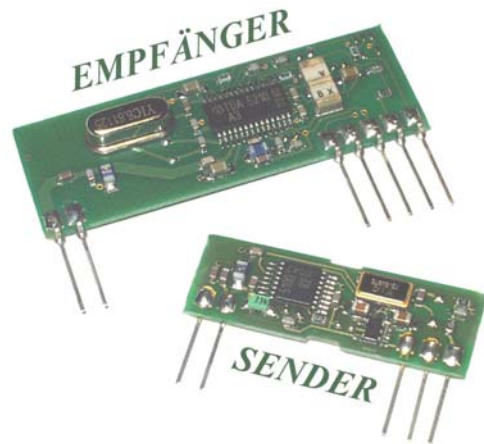

Applications

- VEHICLE ALARM SYSTEMS
- REMOTE GATE CONTROLS
- GARAGE DOOR OPENERS
- DOMESTIC AND COMMERCIAL SECURITY
- WIRELESS TELEMETRY
- REMOTE DATA TRANSFER

Compatible Receiver Modules

- XR6
- XR6B
- XR6LC

General Description

The XT6B miniature transmitter UHF radio module enables the implementation of a simple telemetry link at data rates of up to 64Kbit/s when used with the compatible receiver modules.

The XT6B is fully backward compatible with the XT6 range of shielded transmitters and is fully compliant with EN 300-220.

In conjunction with the XR6LC receivers, a high quality FM link is now available at the lowest price possible.

The XT6B module will suit one-to-one and multi-node wireless links in applications including building and car security, remote industrial process monitoring and computer networking. Because of its small size and low power requirements, this modules is ideal for use in portable battery powered wireless applications.

Ordering Information

Standard Product;

Part No	Description
XT6B-868.45	SIL Transmitter XXX.XX MHz
XT6B-869.85	
XT6B-914.5	
* Specify frequency 868.45, 869.85 or 914.5 MHz	

Absolute Maximum Ratings: Transmitter

Operating temperature:	-20°C to +55°C
Storage temperature:	-40°C to +100°C
Supply Voltage (pin 3)	12V
Data input (pin 5)	10V
RF Out (pin 2)	±50V @ < 10MHz , +20dBm @ > 10MHz

Electrical Characteristics: Transmitter

	pin	min.	Typ.	max.	units	notes
Transmitter						
Supply voltage	3	2.2	3/5	10.0	Volts	
Supply current	3	7.0		8.5	mA	1
RF power	2	1	2	3	mW	1
RF & Data						
2 nd harmonic			-50		dBc	2
Harmonics @ > 1GHz			-50		dBc	2
Initial frequency accuracy			±25		KHz	
Overall freq accuracy over -10 to +55 degC			±50		KHz	
Modulation bandwidth @ -3dB			20		KHz	
Power up time to full RF			5		mS	
Data rate				40000	bits/s	
Data pulse width		250			µs	

- Note 1:** measured into a 50Ω impedance
- 2:** the limit for the European spec EN 300 220 is -36dBm

Application Circuit

The application circuit shows how the XT6B transmitter can easily be integrated into a system to form a wireless link

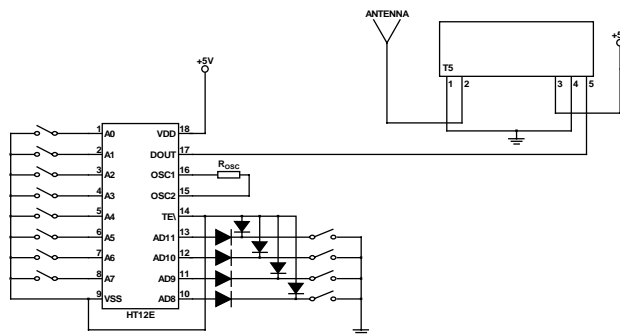

Transmitter Application Circuit

Connection Details

Mechanical Dimensions

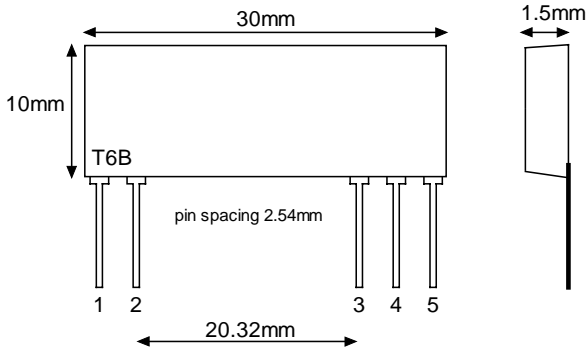

XT Transmitter

Pin Description:

RF GND (pin 1)

RF ground pin, internally connected to pin 4 (0V). This pin should ideally be connected to the nearest ground plane (e.g. coax braid, main PCB ground plane etc.)

RF OUT (pin2)

50Ω RF antenna output. To achieve best results the antenna impedance must match that of the module.

V_{CC} (pin 3)

+Ve supply pin. The module will generate RF when V_{CC} is present. It is strongly recommended that a 100nF capacitor decouples the supply rail as close as possible to this pin.

GND (pin 4)

Supply and data ground connection, connected to pin 1.

Data IN (pin 5)

This input has an impedance of 47KΩ and should ideally be driven by a CMOS logic drive or compatible. The drive circuitry should be supplied with the same supply voltage as the Tx module.

Application Information

Antenna Design

The design and positioning of the antenna is as crucial as the module performance itself in achieving a good wireless system range. The following will assist the designer in maximising system performance.

The antenna should be kept as far away from sources of electrical interference as physically possible. If necessary, additional power line decoupling capacitors should be placed close to the module.

The antenna 'hot end' should be kept clear of any objects, especially any metal as this can severely restrict the efficiency of the antenna to receive power. Any earth planes restricting the radiation path to the antenna will also have the same effect.

Best range is achieved with either a straight piece of wire, rod or PCB track @ ¼ wavelength (7cm @ 868 MHz). Further range may be achieved if the ¼ wave antenna is placed perpendicular in the middle of a solid earth plane measuring at least 10cm radius. In this case, the antenna should be connected to the module via some 50 ohm characteristic impedance coax

Helical Antenna

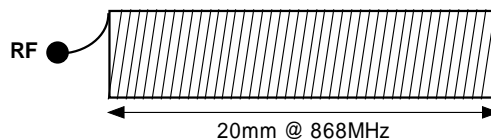

9 turns equally spaced
 Ø = 5mm (inside)

Whip Antenna

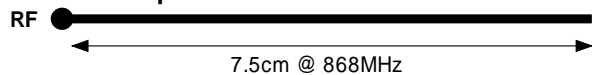

Antenna Configurations To Be Used With The XT6 Transmitter Modules

Features

- Miniature SIL package
- Single conversion FM Super-het using RF LC filter and ceramic IF filtering at 10.7 MHz.
- Dynamic range better than 100dB
- Analogue, Digital and true RSSI outputs
- DATA RATES UP TO 20KBITS/S
- OPTIMAL RANGE 200m
- Operation on 868/914 MHz
- HIGH SENSITIVITY (-103 dBm)
- Very low current consumption (6mA)
- SINGLE 5V SUPPLY

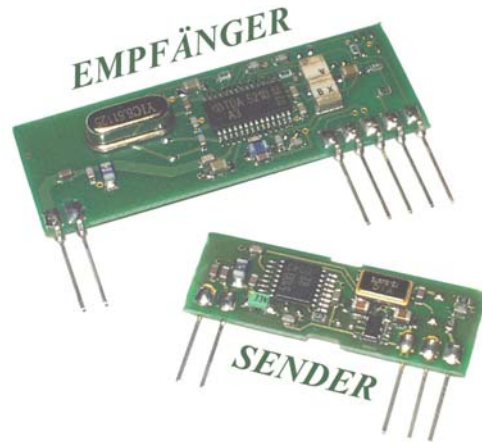

Compatible Transmitter Modules

- XT6
- XT6H
- XT6B

Applications

- Telemetry systems
- Remote switching applications
- Paging systems
- Domestic and commercial security

General Description

The XR6LC miniature receiver UHF radio module enables the implementation of a **reliable** telemetry link at data rates of up to 20Kbit/s when used with one of the compatible X transmitter modules

Available for operation at 868/914 MHz these modules are able to receive at distances of up to 200 meters.

The receiver is based on the classical superhet single conversion architecture utilising a PLL xtal referenced oscillator which yields a highly stable IF frequency (10.7 MHz). This hence allows use of high Q bandpass filters offering excellent adjacent channel rejection and hence high interference Immunity.

The XR6LC module will suit one-to-one and multi-node wireless links in applications including building and car security, remote industrial process monitoring and computer networking. Because of its small size and low power requirements, including a fast RSSI/CD, the module is ideal for use in portable battery powered wireless applications.

Ordering Information

Standard Product;

Part No	Description
XR6LC-XXX.XX	XXX.XX MHz SIL receiver
XXX.XX – 868.45, 869.85 or 914.5 MHz	

Absolute Maximum Ratings: Receiver

Operating temperature:	-10°C to +55°C -40 to +80 deg C option available
Storage temperature:	-40°C to +100°C
Supply Voltage (pin 5)	7V
RF Input (pin 1)	+20 dBm (100mW)

Electrical Characteristics: Receiver (20 Kbits/sec version)

	pin	min.	typ.	max.	units	notes
DC LEVELS						
Supply voltage		4.5	5	5.5	V	
Supply current			6.0		mA	
Supply ripple		-	-	10	mV _{P-P}	
Data output high			=>4.0		V	
Data output low			<= 0.5		V	
RF						
RF sensitivity			-103		dBm	
IF Bandwidth			230		KHz	
Initial frequency accuracy			±22		KHz	
Max R.F. input			10		dBm	
E.M.C.						
Spurious responses upto 1GHz			<60		dB	
LO leakage, conducted			<60		dBm	
LO leakage, radiated			<60		dBm	
Image rejection			60		dB	
DYNAMIC TIMING						
Power up to stable data (With RF signal present)			30	35	mS	20 kbps
Signal to stable data (With power supply already on)				2.5	mS	20 kbps
Power up to valid RSSI (with RF signal present)				1	mS	All versions
Allowable data pulse widths (note 2)		50		6000	uS	20 kbps

Notes

The data slicer is optimised for a 50:50 duty cycle, hence for reliable communications, data should be encoded using a suitable scheme such as Manchester Encoding, although pulse width modulation up to 30:70 / 70:30 can be tolerated.

Connection Details

Mechanical Dimensions

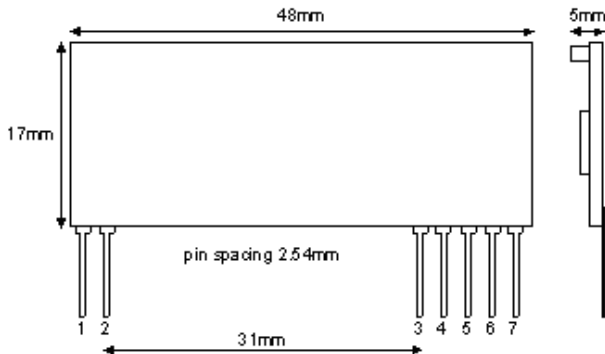

XR6LC Receiver

Application Circuit

The application circuit shows how the XR6LC Receiver can easily be integrated into a system to form a wireless link.

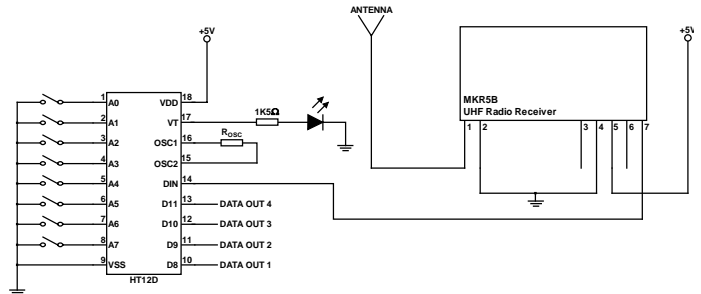

Receiver Application Circuit

Pin Description

RF IN (pin 1)

50Ω RF input from antenna, connect using shortest possible route. This input is isolated from the internal circuit using the air gap of the front end SAW RF filter.

RF GND (pin 2)

RF ground connection, preferably connected to a solid ground plane.

RSSI / Carrier Detect (pin 3)

The Received Signal Strength Indicator provides a DC output voltage proportional to the RF input signal. The amplitude of the RSSI voltage increases with increasing RF signal strength. A simple transistor interface can yield a carrier detect logic output.

Gnd (pin 4)

Connect to power supply ground

V_{CC} (pin 5)

+Ve supply pin. Operation from a 5V supply able to source 14mA at less than 10mV_{P-P} ripple.

AF (pin 6)

Audio frequency output

DATA OUT (pin 7)

CMOS compatible output. This may be used to drive external decoders.

Vertrieb:

AGT electronic Handelsges. mbH
Spannstücken 22
22159 Hamburg

T: 040 644 34 64 / F: 040 644 61 33 / M: info@agt-electronic.de / W: www.agt-electronic.de

RSSI Values

The XR6LC RSSI output provides a DC output proportional to the RF input signal. The table below shows the typical RSSI value depending on the RF signal strength.

RF Signal Strength / dBm	RSSI / V
-120	1.27
-110	1.37
-100	1.49
-90	1.74
-80	1.99
-70	2.3
-60	2.56
-50	2.63
-40	2.63
-30	2.53